

# Device/PLC Connection Manuals

---



## About the Device/PLC Connection Manuals

Prior to reading these manuals and setting up your device, be sure to read the "Important: Prior to reading the Device/PLC Connection manual" information. Also, be sure to download the "Preface for Trademark Rights, List of Units Supported, How to Read Manuals and Documentation Conventions" PDF file. Furthermore, be sure to keep all manual-related data in a safe, easy-to-find location.



## 5.6 Toshiba

### 5.6.1 System Structure

The following describes the system structure for connecting the GP to Toshiba PLCs.

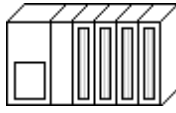

**Reference** *The Cable Diagrams mentioned in the following tables are listed in the section titled "5.6.2 Cable Diagrams".*

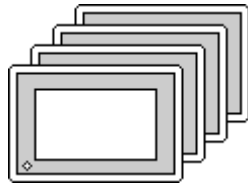
#### ■ PROSEC T Series (using CPU unit Link I/F)

CPU	Cable Diagram	GP
		
T3 (Version 1.8+) *1	(Cable Diagram 1)	GP Series

\*1 Connect to the CPU Module's computer link port.

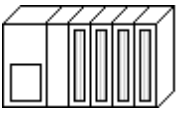
#### ■ V Series (using CPU unit Link I/F)

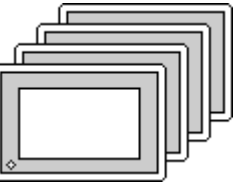
CPU	Cable Diagram	GP
		
S3PU45A S3PU55A S3PU65A S2PU22A S2PU32A S2PU72A S2PU72D	(Cable Diagram 1)	GP Series

**5.6.2 Cable Diagrams**

The cable diagrams illustrated below and the cable diagrams recommended by Toshiba may differ, however, using these cables for your PLC operations will not cause any problems.

**Cable Diagram 1**

- When using Digital's RS-422 connector terminal adapter, GP070-CN10-O

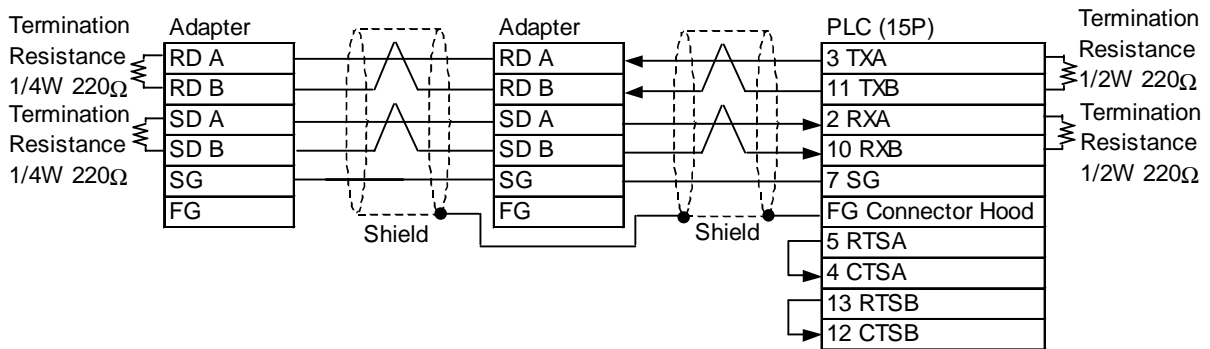

- When using Digital's Multi-link Cable, GP230-IS12-O

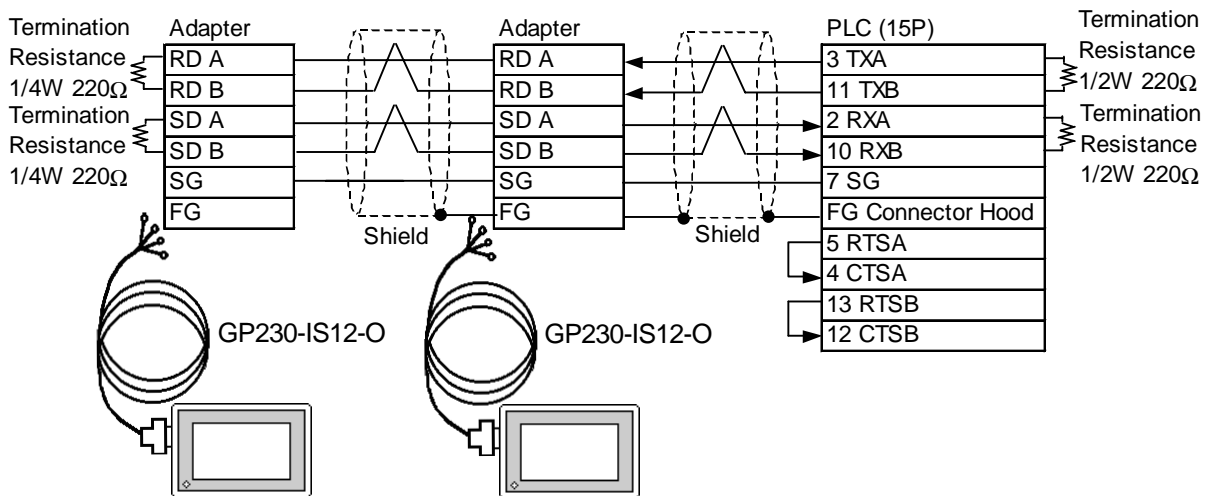

*Ground your PLC's FG terminal according to your country's applicable standard. For details, refer to the corresponding PLC manual.*



- **Pull out a small amount of the Transfer Cable's shield, make a wire out of it and connect it to the PLC's FG terminal.**



- The GP230-IS12-O Cable FG terminal is not connected to the GP's FG.
- Attach a Termination Resistor at both ends of the cable.
- For the RS-422 connection, refer to Toshiba's PLC manual for the cable length.
- As a general rule, connect the PLC at the end of the circuit.

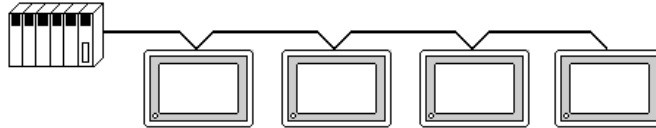

When making your own cable, Hitachi Densen's CO-SPEV-SB-(A) 3P\*0.5 cable is recommended as the connection cable.

The cable connection lines are as illustrated below. The cables between the GP and the terminals should be less than 10m.

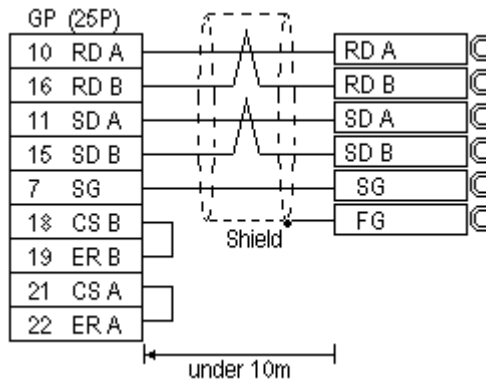





**5.6.3 Supported Devices**

The following describes the range of devices supported by the GP.

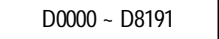
**PROSEC T Series**

 Setup System Area or Communication Information's Storing Address here.

Device	Bit Address	Word Address	Particulars	
External Input	X00000 ~ X255F	XW0000 ~ XW255	L/H	
External Output	Y00000 ~ Y255F	YW0000 ~ YW255		
Internal Relay	R00000 ~ R511F	RW0000 ~ RW511		
Special Relay	S0000 ~ S255F	SW000 ~ SW255		
Link Register Relay	Z0000 ~ Z511F	---		
Link Relay	L0000 ~ L255F	---		
Timer (contact)	T000 ~ T255	---		
Counter (contact)	C000 ~ C255	---		
Timer (current value)	---	T000 ~ T511		
Counter (current value)	---	C000 ~ C511		
Data Register	---	 D0000 ~ D8191		
Link Register	---	W0000 ~ W1023		
File Register	---	F0000 ~ F8191		

**V Series**

 Setup System Area or Communication Information's Storing Address here.

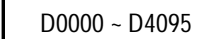
Device	Bit Address	Word Address	Particulars
External Input	X0000 ~ X8191F	XW000 ~ XW8191	L/H
External Output	Y0000 ~ Y8191F	YW000 ~ YW8191	
Internal Relay	R0000 ~ R4095	RW000 ~ RW4095	
Special Relay	S0000 ~ S511F	SW000 ~ SW511	
Data Register	—————	 D0000 ~ D4095	



**Note:** The Device Range may differ depending on the CPU type. For details, refer to the Toshiba's PLC manual.



- **PLC I/O and Controller Internal Memory data is treated as a variable. The variables that the GP unit can handle are as follows. When handling all PLC variables with the GP, use the following variables in the ladder program.**

**Please note that memory variables differ from GP unit's device name.**

GP Device Name		PLC Controller Memory Variable Name	Details
X, XW	←→	I/O Variable (IQ)	X, XW and Y, YW use the same memory area (have the same range).
Y, YW			
R, RW	←→	Data Register Variable (DW)	R, RW device and D device use the same area. Designate the R device when performing bit write from the GP unit.
D			
S, SW	←→	Special Register Variable	

- \* *Although local variables, control global variables and station global variables exist outside of the above-mentioned device, they are not accessible from the GP unit.*

### 5.6.4 Environment Setup

The following lists Digital's recommended PLC and GP communication settings.

#### ■ PROSEC T Series

GP Setup		CPU Module Setup	
Baud Rate	19200 bps <sup>1</sup>	Baud Rate	19200 bps <sup>1</sup>
Data Length	8 bits	Data Bit	8 bits
Stop Bit	2 bits	Stop Bit	2 bits
Parity Bit	Odd	Parity Bit	Odd
Data Flow Control	ER Control		---
Communication Format	4-wire type		---
Unit No.	1	Station Number	1

\* 1 According to this PLC's specifications, if the PROSEC T3 is Ver. 1.4 or lower, data transmission is possible only at 9600 bps or less.

#### ■ V Series

GP Setup		PLC Setup	
Baud Rate	19200 bps	Baud Rate	19200 bps
Data Length	8 bits	Data Bit	8 bits
Stop Bit	2 bits	Stop Bit	2 bits
Parity Bit	Odd	Parity Bit	Odd
Data Flow Control	ER Control		---
Communication Format	4-wire type		---
Unit No.	1	Station Number	1